

HIGH VOLTAGE ISOLATION INTERFACE

Brief Description:

Emerging Technologies, LLC. was called upon to develop a high voltage isolation interface. The new interface isolates up to 10,000 VAC HiPot tester voltage from remote sense measurement hardware, used during functional test, while the DUT undergoes HiPot testing.

The purpose of the interface is to isolate the remote sense connection of the existing AC power source used during the DUT functional test to safely perform HiPot testing without damaging the AC power source.

The interface incorporates relays, wire, and connectors with rating to handle up to 10,000 VAC. No high voltage is connected to the PCB. The relays are switched using the customers existing 24 VDC I/O hardware. The low voltage is routed via traces on the PCB. Additionally, DIN rail mounting clips were incorporated to facilitate easy field installation.

Emerging Technologies developed the printed circuit board layout for review by the customer, procured the components, and assembled and tested the interface. After proving the interface in the field additional interfaces were fabricated to update all of the existing test systems for the manufacturing unit.

Customer Benefit:

The customer was able to automatically perform production testing utilizing accurate voltage measurement at the DUT during functional test while maintaining the ability to perform HiPot testing without damaging the AC power source using the Emerging Technologies, LLC. custom designed interface when no off the shelf interface was available.

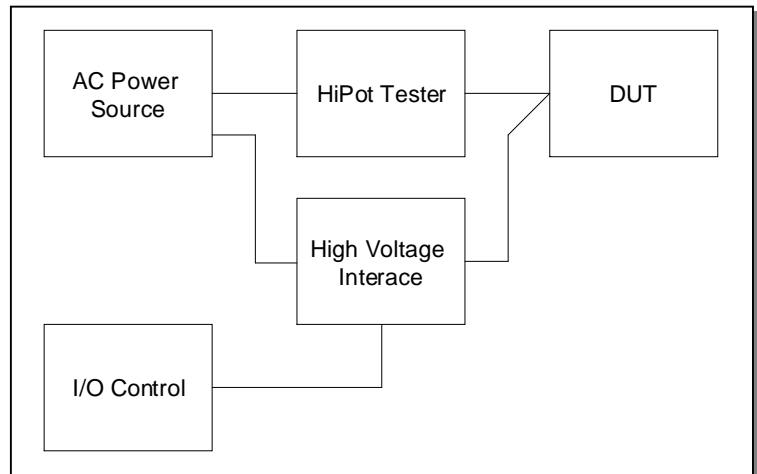
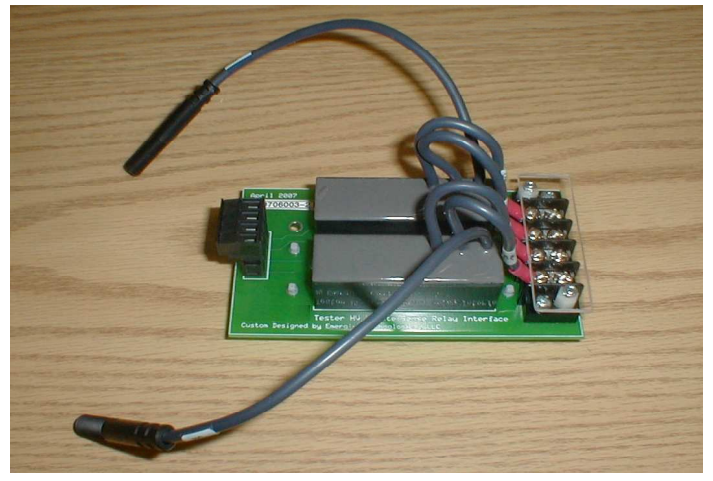

Components Used:

- Custom developed printed circuit board.
- Modular low voltage header.
- High voltage relays.
- High voltage wire.
- High voltage quick disconnects

Emerging Technologies, LLC.

Responsibilities:

- Functional Specification Generation
- ✓ Design / Engineering
- ✓ Fabrication
 - Programming – Software
 - Programming – Firmware
- ✓ Field Installation
- ✓ On-Site Commissioning
- Post Commissioning Support
- Other

Technologies:

- Embedded Computers
- Microcontrollers
- Visual Software
- Control Software
- Data Acquisition
- Computer Based Control
- Communications
- ✓ System Integration
- Other

Customer Category:

- OEM
- ✓ Industrial Manufacturer
- Custom Equipment
- Utility
- R&D

SPECIALISTS IN TEST, MEASUREMENT, AND DATA ACQUISITION

Emerging Technologies, LLC.

PH: (920) 684-0216

www.emergingtech-llc.com